

SAMPLE

PAPER

H



DIGITAL TECHNOLOGIES

DO NOT OPEN THIS BOOKLET
UNTIL INSTRUCTED.

STUDENT'S NAME:

Read the instructions on the **ANSWER SHEET** and fill in your **NAME, SCHOOL** and **OTHER INFORMATION**.

Use a pencil. Do **NOT** use a coloured pencil or a pen.

Rub out any mistakes completely.

You **MUST** record your answers on the **ANSWER SHEET**.

Mark only **ONE** answer for each question.

Your score will be the number of correct answers.

Marks are **NOT** deducted for incorrect answers.

Use the information provided to choose the **BEST** answer from the four possible options.

On your **ANSWER SHEET** fill in the oval that matches your answer.

1. Ava created a spreadsheet in order to track her school supply expenses.

	A	B	C	D
1	Item name	No of items	Cost per item	Subtotal
2	Notebooks	4	\$1.50	\$6.00
3	Pens	3	\$1.00	\$3.00
4	Pencil case	1	\$3.00	\$3.00
5				
6			TOTAL COST	\$12.00
7				
8			Mean cost per item	\$1.50

Cell D6 contains the total amount of money that Ava spent on her school supplies. What formula was used in cell D6 to calculate the TOTAL COST?

- (A) =SUM(D2:D4) (B) =SUM(C2:C4) (C) =SUM(B2:B4) (D) =SUM(B2:D4)

2. Rani wanted to use this photo as the background to the text in a word processing document.



Photo 1

She opened the Format Picture dialogue box.

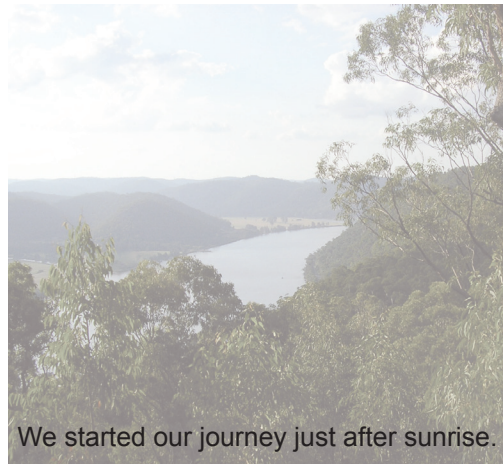
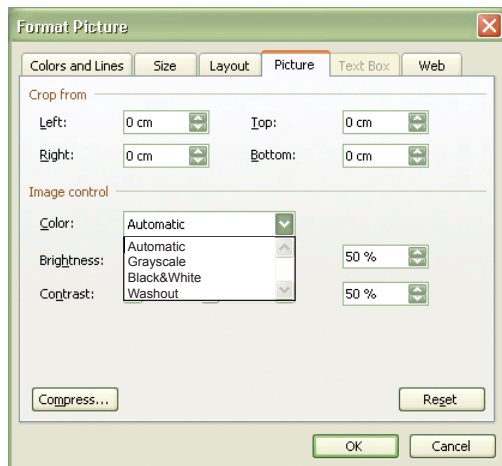

Photo 2

Which setting from the 'Color' menu in Image control should Rani select so that the text can be read over the picture, as shown in Photo 2?

- (A) Automatic (B) Grayscale (C) Black & White (D) Washout

3. Finn is creating a web page for a class project. These screenshots show Finn's source code and web page.

```
1 <html>
2 <head>
3 <title> First Web Page </title>
4 </head>
5 <body style="background: lightyellow">
6 <p> My First Web Page </p>
7 <p> This is my first web page. I have had a <em> really </em> good time creating my first page.
8 </p>
9 <p> My teacher said: <strong style="color: purple"> CONGRATULATIONS! </strong> </p>
10 </body>
11 </html>
```

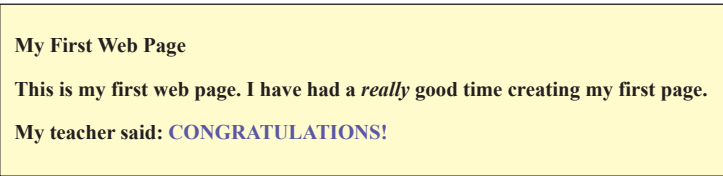

Why did Finn use the command in the code?

- (A) to move the text
- (B) to indent the text
- (C) to hyperlink the text
- (D) to emphasise the text

4. Mia created this flow chart to help her develop a simple program for Mathematics.

X, T and N are variable names used to store numbers.

Which symbol on the flow chart below represents a decision?

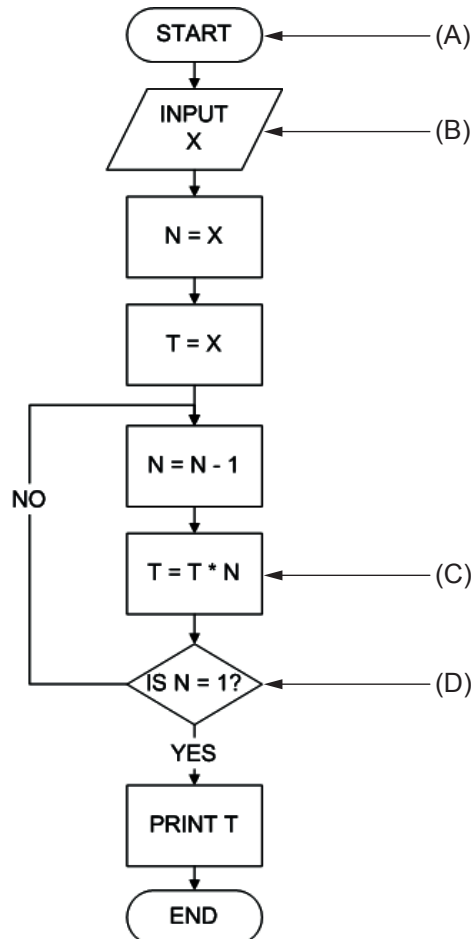

5. Lily created an animation to use as a logo for a website.

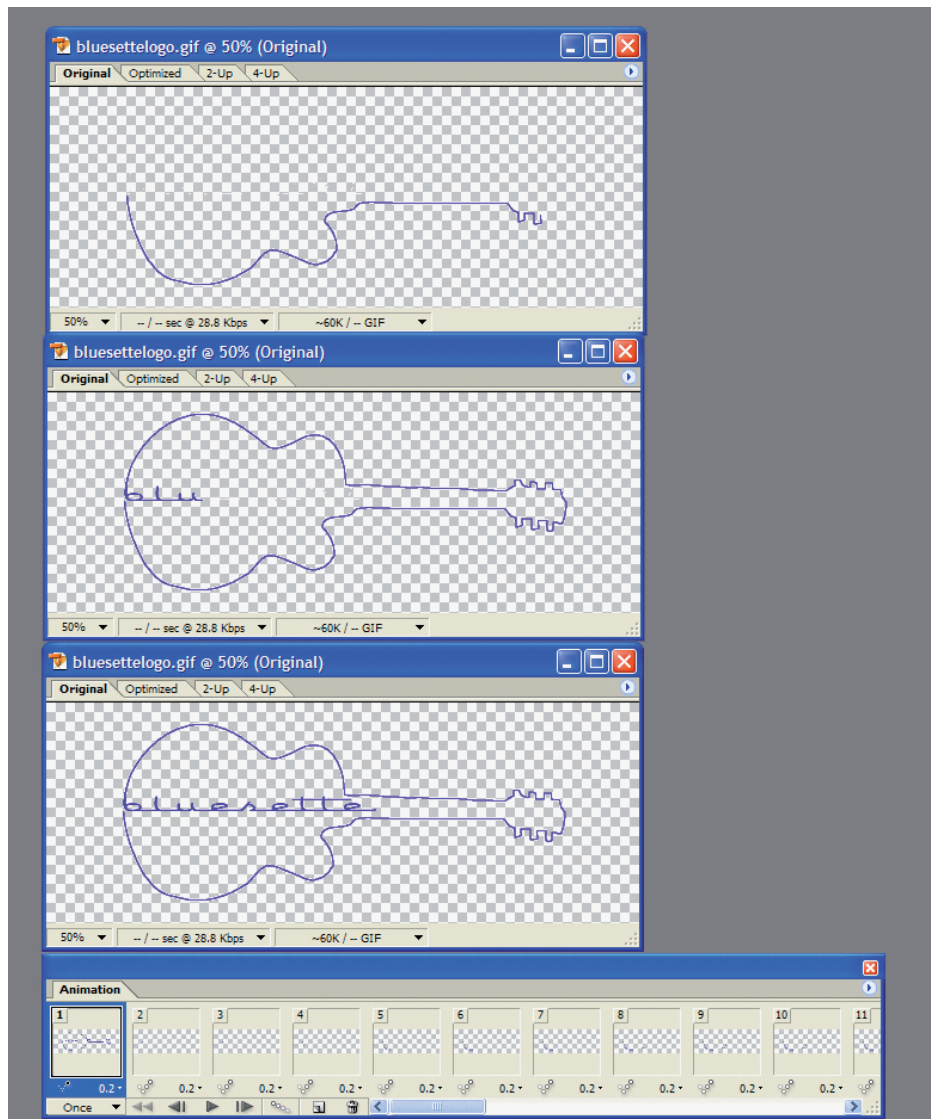

Lily formatted the animation with a transparent background to prevent the webpage colour being obscured.

Which part of the animation frame represents the transparent areas?

- (A) all the checked areas
- (B) the outline of the guitar
- (C) the checked areas inside the outline of the guitar
- (D) the checked areas outside the outline of the guitar

END OF PAPER

TO ANSWER THE QUESTIONS

Example:

Using a computer to type a report is an example of

- (A) emailing.
- (B) a calculation.
- (C) word processing.
- (D) a computer game.

The answer is word processing, so you would fill in the oval **C**, as shown.

A B C D



USE A PENCIL
DO NOT USE A COLOURED PENCIL OR PEN

START

- | | | | | |
|---|-------------------------|-------------------------|-------------------------|-------------------------|
| 1 | <input type="radio"/> A | <input type="radio"/> B | <input type="radio"/> C | <input type="radio"/> D |
| 2 | <input type="radio"/> A | <input type="radio"/> B | <input type="radio"/> C | <input type="radio"/> D |
| 3 | <input type="radio"/> A | <input type="radio"/> B | <input type="radio"/> C | <input type="radio"/> D |
| 4 | <input type="radio"/> A | <input type="radio"/> B | <input type="radio"/> C | <input type="radio"/> D |
| 5 | <input type="radio"/> A | <input type="radio"/> B | <input type="radio"/> C | <input type="radio"/> D |

SAMPLE



DT

PAPER

H

Your privacy is assured as UNSW Global Pty Limited fully complies with appropriate Australian privacy legislation. Visit www.eaa.unsw.edu.au for more details.

ICAS Digital



UNSW Global
AUSTRALIA

ited

QUESTION	KEY	DESCRIPTION OF SKILL	AREA	LEVEL OF DIFFICULTY
1	A	Identify the correct formula for calculating the total cost	5	Easy
2	D	Understand the use of the 'washout' colour setting	3	Medium
3	D	Understand the result of code when designing websites.	4	Medium
4	D	Identify the symbol for a 'decision' in a flow chart	6	Medium
5	A	Understand the effect of a watermark on an animation cell	3	Hard

LEGEND

Area refers to the particular curriculum area or strand assessed by the question.

1. General Skills
2. Word Processing
3. Graphics/Multimedia
4. Internet/Email
5. Spreadsheets/Databases
6. Programming/Scripting

Level of difficulty refers to the expected level of difficulty for the question.

- | | |
|--------------------|--|
| Easy | more than 70% of candidates will choose the correct option |
| Medium | about 50–70% of candidates will choose the correct option |
| Medium/Hard | about 30–50% of candidates will choose the correct option |
| Hard | less than 30% of candidates will choose the correct option |

ACKNOWLEDGMENT

Copyright in this booklet is owned by UNSW Global Pty Limited, unless otherwise indicated. Every effort has been made to trace and acknowledge copyright. UNSW Global Pty Limited apologises for any accidental infringement and welcomes information to redress the situation.

THE FOLLOWING YEAR LEVELS SHOULD SIT THIS PAPER:

Australia	Year 10
Brunei	Form 5
Hong Kong	Form 4
Indian Subcontinent¹	Class 10
Indonesia	Year 11
Malaysia	Form 4
Middle East²	Class 10
New Zealand/Pacific³	Year 11
Singapore	Secondary 3
Southern Africa⁴	Grade 10

¹ Indian Subcontinent Region: India, Sri Lanka, Nepal, Bhutan and Bangladesh.

² Middle East Region: United Arab Emirates, Qatar, Kuwait, Saudi Arabia, Egypt, Bahrain, Oman, Turkey, Lebanon, Tunisia, Morocco, Libya, Algeria and Jordan.

³ Pacific Region: Vanuatu, Papua New Guinea and Fiji.

⁴ Southern Africa Region: South Africa, Botswana, Lesotho, Swaziland, Zimbabwe and Namibia.



© 2017 UNSW Global Pty Limited. Copyright in this document is owned by UNSW Global Pty Limited.



UNSW Global
AUSTRALIA